

KITZ

XJ Series **Aluminum Butterfly Valves**



KITZ CORPORATION

Aluminum Butterfly Valves

XJ Series

KITZ XJ series aluminum butterfly valves: Featuring a unique style for the neck designs (U.S.P. No. 6676109) to accommodate various piping designs, piping positions, and installation environments.

Your choice of two neck designs :

A long neck type and a short neck type are available for use in a variety of applications.

Easy valve-to-flange centering :

The light weight of the die-cast aluminum valve body (which is only one third of the weight of KITZ's conventional cast-iron butterfly valves) eases valve-to-flange centering work on mounting valves on pipelines.

Wide range of service applications :

Austenitic stainless steel discs and EPDM* rubber seats can handle many different types of line fluid without risk of corrosion.

*EPDM:ethylene propylene diene terpolymer

Stabilized operating torque :

A pair of stem bearings assembled around the top and bottom stems prevents stem galling and stabilizes the valve operating torque for smooth and trouble-free disc rotation.

On-the-spot actuator assembly :

The actuator mounting pads of all necks are designed in conformity with ISO 5211 requirements for direct on-site mounting of actuators that are provided with ISO 5211 valve mounting flanges.

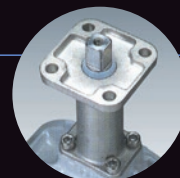

Prevention of dew condensation (Long neck type) :

A long stainless steel neck blocks transfer of fluid heat to the valve operating device, so no insulation is needed on the operating device. Dew condensation is also minimized for gear-operated valves used in cold water service.

Rust prevention :

The main parts such as the stems, discs, necks, neck connectors, and endplates and small parts such as stopper plates, washers, and boltings are all made of stainless steel for high-grade rust prevention.

S-shaped spherical disc for high sealing performance (patented) :

KITZ's original cross-sectionally S-shaped valve discs with spherical surfaces make evenly tight contact with rubber liners for excellent sealing performance with reduced operating torque. Complete 360° shut-off mechanisms help to extend the service life of rubber liners. (Size: ≥2 inches)



Short Neck



Long Neck



BADG12

Long Neck Type

Prevented dew condensation



- A long stainless steel neck reduces the conductivity of fluid heat and prevents dew condensation.
- Variety of valve body and neck insulation designs available.
- Choice of actuators for automated valve operation.

Applications:

- Building utilities.
- Piping networks for cold water, hot water, and other water supply.

Short Neck Type

Compact design



- Suitable for piping in a limited space.
- Choice of actuators for automated valve operation.

Applications:

- Building utilities.
- Plant facilities.
- Water treatment facilities.
- Industrial machinery operation.

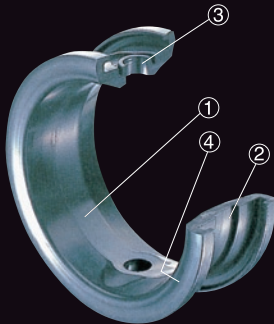

Carefully designed KITZ EPDM seats have the following unique features that ensure their functional stability, high sealing performance, and long life:

- Self-reinforced ribbing
- Wide disc seating contact
- Dual stem seal bearings

- ① Wide disc seating contact for high sealing performance.
- ② Reinforced ribbing minimizes valve operating problems such as distortion, skidding, and exfoliation of rubber liners caused by line pressure load and friction with metal discs.
- ③ Stem seal bearings are assembled on the top and bottom stems for stable sealing.
- ④ Gasketless flange sealing contact for easy valve mounting.

Product Range

● Standardized. ○ Optionally available.

Design	Class	Operator	Size Product code	mm												Page
				40	50	65	80	100	125	150	200	250	300			
				inch	1 1/2	2	2 1/2	3	4	5	6	8	10	12		
Long neck	JIS 10K	Lever	10XJME	○	○	○	○	○	○	○	○					6
		Gear	G-10XJME	○	○	○	○	○	○	○	○	○	○	●		6
		Pneumatic actuator (Double action)	FA-10XJME	○	○	○	○	○	○	○	○	○	○	○	○	8
		Pneumatic actuator (Spring return)	FAS-10XJME	○	○	○	○	○	○	○	○	○				8
		Electric actuator	EXS□-10XJME	○	○	○	○	○	○	○	○	○	○	○	○	10
	JIS 10K/ ASME Class 150	Lever	10XJMEA	●	●	●	●*	●*	●	●	●*					6
		Gear	G-10XJMEA	●	●	●	●*	●*	●	●	●	●*	●			6
		Pneumatic actuator (Double action)	FA-10XJMEA		○	○	○*	○*	○	○	○	○*	○			8
		Pneumatic actuator (Spring return)	FAS-10XJMEA		○	○	○*	○*	○	○	○	○*				8
		Electric actuator	EXS□-10XJMEA		○	○	○*	○*	○	○	○	○*	○			10
	EN1092 PN16	Lever	PN16XJME		●	●	●**	●	●	●**	●					6
		Gear	G-PN16XJME		●	●	●**	●	●	●**	●	●**				6
Short neck	JIS 10K	Lever	10XJSME	○	●	●	●	●	●	●	●					7
		Gear	G-10XJSME	○	●	●	●	●	●	●	●	●	○	○		7
		Pneumatic actuator (Double action)	FA-10XJSME	○	○	○	○	○	○	○	○	○	○	○		9
		Pneumatic actuator (Spring return)	FAS-10XJSME	○	○	○	○	○	○	○	○	○				9
		Electric actuator	EXS□-10XJSME	○	○	○	○	○	○	○	○	○	○	○	○	10

* Centering sleeves are optionally available for accurate centering with the ASME Class 150 flanges.

**Centering sleeves are supplied for accurate centering with EN1092 PN16 flanges.

□ of product coding are power sources of actuator coding, please refer to Product Coding.

Product Coding

G-10 XJ S M E A

① ② ③ ④ ⑤ ⑥ ⑦

① Valve operation

None Lever
 G Gear
 FA Pneumatic actuator (Double action)
 FAS Pneumatic actuator (Spring return action)
 EXS100/200 Type EXS KELMO® electric actuator (Reversible type)

② Class

PN16 EN PN16
 10 JIS 10K
 10□A JIS 10K/ASME Class 150

③ Valve series

XJ Aluminum die-cast XJ Series

④ Design

None Long neck
 S Short neck

⑤ Disc material

M 316 Stainless steel

⑥ Seat material

E EPDM

Technical Specification

Class	JIS 10K	Class 150	PN16
Maximum service pressure	1MPa	1MPa	1.6MPa (16bar)
Service temperature range*1	-20°C~+120°C		
Continuous service Temperature range*2	-20°C~+100°C		
Face-to-face dimension	API609, BS5155 (Short pattern) ISO 5752-20, JIS B 2002 46 series		
Coupling flanges	JIS B 2220 / 2239 10K	ASME Class 150 JIS B 2220 / 2239 10K	EN1092 PN16*3

*1 Condition: Fluid is not frozen.

*2 Refer to P-T rating chart.

*3 With centering sleeves.

Refer to the product range chart on page 3 and precautions on page 14 for details.

P-T Rating

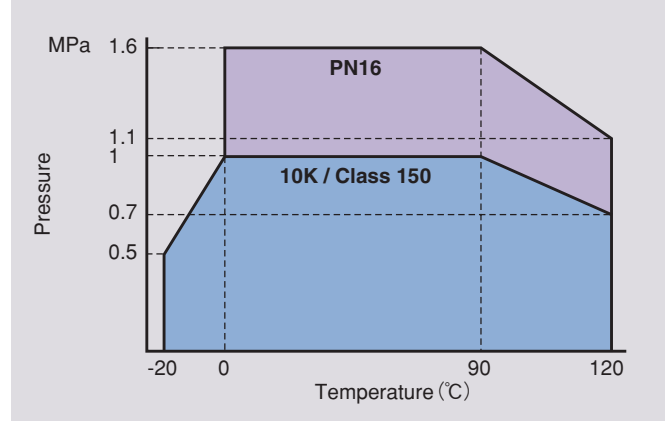

Note : Contact the KITZ Corporation for technical advice when service conditions may exceed the limits of the P-T rating range shown here.

Cv Value

Valve size		Valve opening
mm	inch	90°
40	1½	76
50	2	99
65	2½	205
80	3	372
100	4	723
125	5	1100
150	6	1820
200	8	2780
250	10	4350
300	12	6860

Pressure Loss (for handling static clean water)

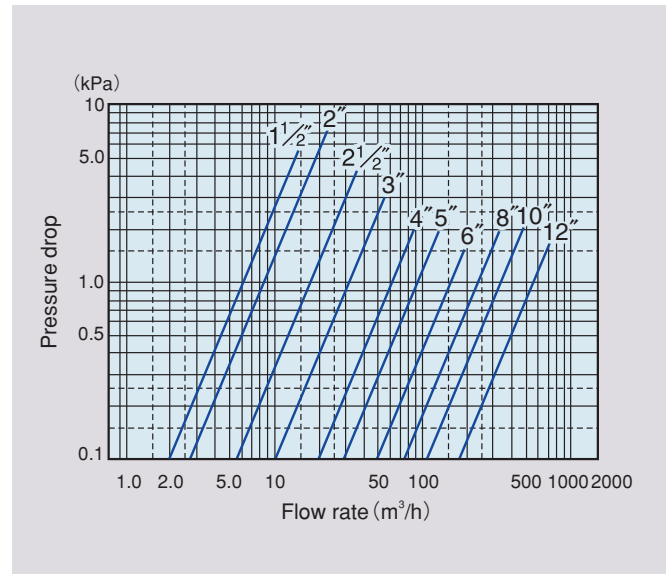

Flow Characteristics

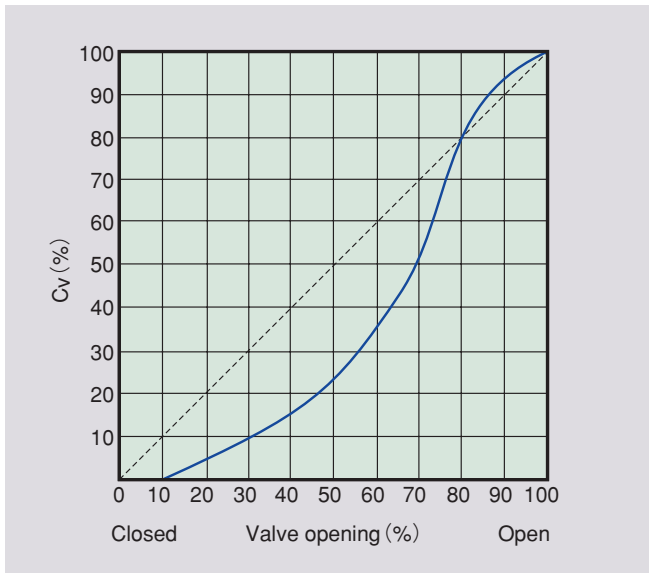

Material

Parts	Material
Body	Aluminum Die-cast / Equivalent ASTM B85-84-383.0
Neck	304 Stainless Steel
Stem	(Equivalent ASTM A276 Type 410)
Disc	A351 Gr. CF8M
O-ring	EPDM
Rubber seat	EPDM
Bottom stem	(Equivalent ASTM A276 Type 410)
Bearing	Metal Backed PTFE (Size 10" and 12") Polyphenylenesulfide (10XJMEA : Size 1½" to 8") Bronze : CAC401C (PN16XJME : Size 2" to 8")

Dew Condensation Test

Samples of KITZ XJ series butterfly valves equipped with long necks (KITZ Product Code: G-10XJMEA) were tested at the KITZ Laboratory under the conditions listed below. The lower surface temperatures of gear boxes, ambient temperatures, and ambient humidities were measured as the variable functions. The dew condensation boundary was estimated as illustrated below.

Test conditions:

Line fluid : +5°C cold water
 Atmospheric temperature range : +20°C to +40°C
 Valve insulation : 50-mm glass wool (JIS A 9501) around the test valve, with gear boxes exposed to open air.

Note:

The estimation shown here is the result of a summary of tests carried out within a test basin at a constant temperature and humidity and does not necessarily represent the absolute values. Note that the dew condensation prevention properties of these valves may be affected by changes in the test conditions, such as the variation in the degree of air transfer, line fluid temperature, atmospheric humidity, or condition of insulation. Acceptance of an allowance of $\pm 5\%$ beyond the boundary area is recommended.

G-10XJMEA Estimated Dew Condensation Boundary

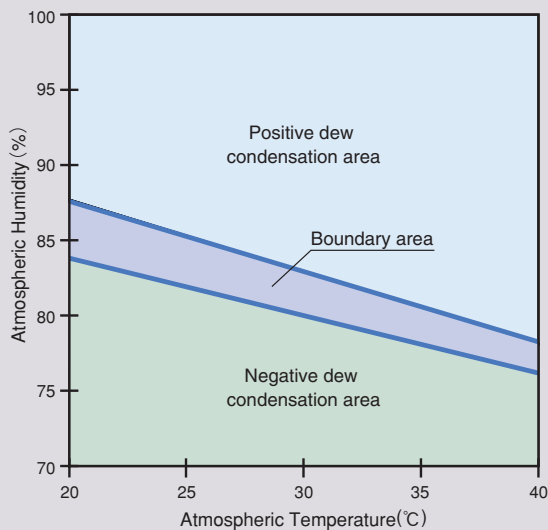

Valve Insulation

Insulation is recommended for areas in blue.

Long Neck Type
(G-10XJMEA)

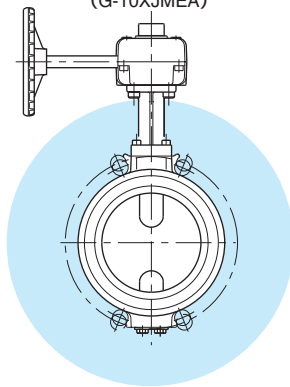

Corrosion Resistance Level

This table indicates the typical corrosion resistance level of the materials used in the discs and rubber liners of the KITZ XJ series butterfly valves with typical line fluids. The data are based on laboratory test results for **material test specimens** (not valve component test specimens) under constantly controlled test conditions. The data may be subject to variation, depending on the actual valve service conditions in the field. Please contact the KITZ Corporation for technical advice if service conditions are extraordinarily severe or if you have any doubts about the corrosion resistance levels of valves on site. In addition, please contact the KITZ Corporation when valves are used for hot water service.

- = Excellent
- = Good
- △ = Less recommended
- × = Not recommended

Fluid	Materials	Disc material	Seat material
		CF8M	EPDM
Acetic acid (10%)		●	●
Air		●	●
Ammonia (anhydrous liquid)		●	●
Ammonium sulfate		●	●
Animal fat		●	×
Calcium chloride		●	●
Carbonic acid		●	●
Chlorinated water		△	×
Ethane		●	×
Ethyl alcohol		●	●
Freon 12		●	●
Gasoline (refined / unleaded)		●	×
Hydrochloric acid 37% (cold)		×	●
Hydrogen gas (cold)		●	●
Lubricating oil (petroleum base)		●	×
Methyl alcohol		●	●
Mineral oil		●	×
Heavy oil		●	×
Natural gas		●	×
Oxygen (cold)		●	●
Petroleum oil (refined)		●	×
Propane gas		●	×
Sea water		●	●
Soybean oil		●	△
Sulfuric acid (7%)		△	●
Sulfuric acid (20%)		×	●
Sulfuric acid (50% \geq)		×	●
Sulfurous		●	△
Steam (100°C)		●	●
Vegetable oil		●	△
Water (fresh) *		●	●

* Chlorine-free

Long Neck Type *Lever Operated*

10XJME (Size: "1½" to "6")
 10XJMEA (Size: "1½" to "8")*
 PN16XJME (Size: "2" to "6")

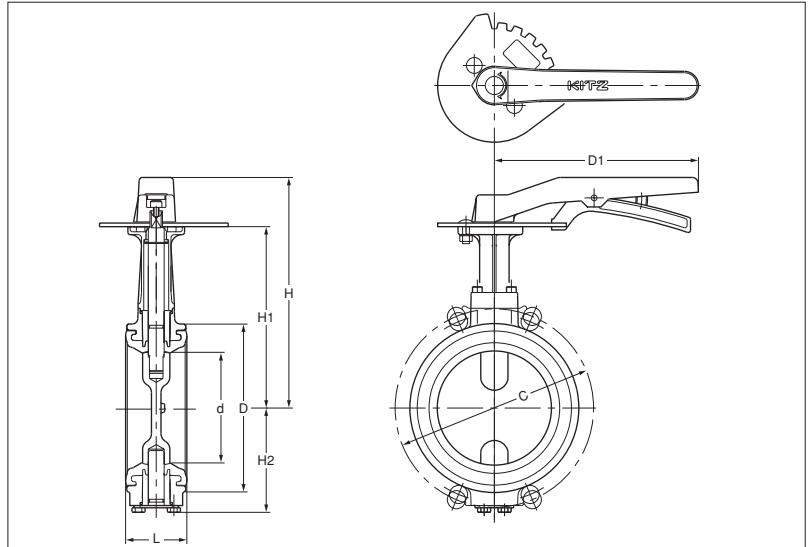

■ Dimensions

unit : mm

Size		d	H	H1	H2	L	D	C			D1
mm	inch							10K	Class 150	PN16	
40	1½	40	172	128	40	33	80	105	98.5	—	180
50	2	50	176	132	66	43	93	120	120.5	125	180
65	2½	65	185	141	74	46	118	140	139.5	145	180
80	3	80	193	149	83	46	129	150	152.5	160	180
100	4	100	204	160	94	52	149	175	190.5	180	180
125	5	125	249	195	122	56	184	210	216	210	230
150	6	150	261	207	135	56	214	240	241.5	240	230
200	8	196	281	234	161	60	258	—	298.5	—	350

* JIS 10K and ASME Class 150. Refer to Page 3 for details.

Long Neck Type *Gear Operated*

G-10XJME (Size: "1½" to "12")
 G-10XJMEA (Size: "1½" to "10")*
 G-PN16XJME (Size: "2" to "8")

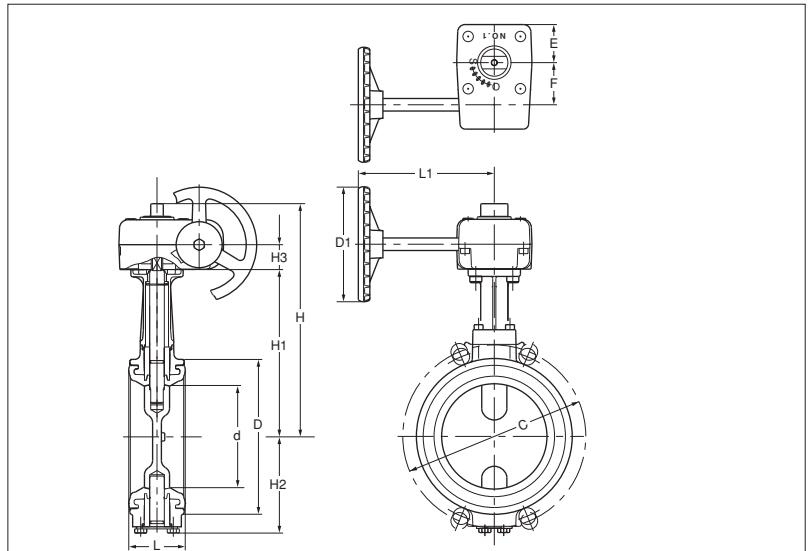

■ Dimensions

unit : mm

Size		d	H	H1	H2	H3	L	D	C			D1	L1	E	F	Gear type
mm	inch								10K	Class150	PN16					
40	1½	40	175	128	40	19	33	80	105	98.5	—	80	122	29	28	No.0
50	2	50	179	132	66	19	43	93	120	120.5	125	80	122	29	28	No.0
65	2½	65	188	141	74	19	46	118	140	139.5	145	80	122	29	28	No.0
80	3	80	196*2	149	83	19	46	129	150	152.5	160	80	122	29	28	No.0
100	4	100	223	160	94	24	52	149	175	190.5	180	110	135	36	40	No.1
125	5	125	258	195	122	24	56	184	210	216	210	110	150	36	40	No.1
150	6	150	270	207	135	24	56	214	240	241.5	240	110	150	36	40	No.1
200	8	196	311	234	161*1	32	60	258	290	298.5	295	170	180	51	63	No.2
250	10	245	405	328	238	32	68	316	355	362	—	170	180	51	63	No.2
300	12	295	430	353	263	32	78	367	400	—	—	170	180	51	63	No.2

*1 G-PN16XJME H2=183

*2 G-PN16XJME H=212

* JIS 10K and ASME Class 150. Refer to Page 3 for details.

Short Neck Type

Lever Operated

10XJSME

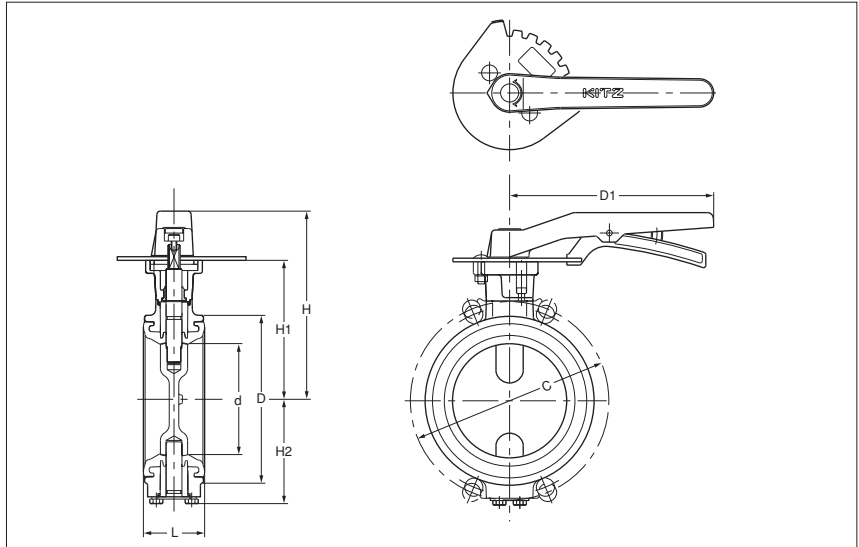

Dimensions

unit : mm

Size		d	H	H1	H2	L	D	C	D1
mm	inch								
40	1½	40	137	93	40	33	80	105	180
50	2	50	139	95	66	43	93	120	180
65	2½	65	147	103	74	46	118	140	180
80	3	80	156	112	83	46	129	150	180
100	4	100	167	123	94	52	149	175	180
125	5	125	205	151	122	56	184	210	230
150	6	150	217	163	135	56	214	240	230

Short Neck Type

Gear Operated

G-10XJSME

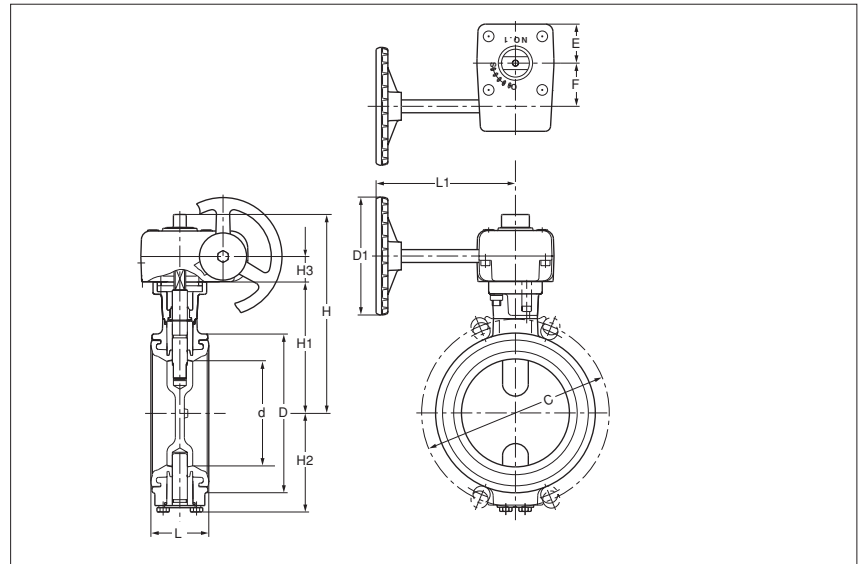

Dimensions

unit : mm

Size		d	H	H1	H2	H3	L	D	C	D1	L1	E	F	Gear type
mm	inch													
40	1½	40	140	93	40	19	33	80	105	80	122	29	28	No.0
50	2	50	142	95	66	19	43	93	120	80	122	29	28	No.0
65	2½	65	150	103	74	19	46	118	140	80	122	29	28	No.0
80	3	80	159	112	83	19	46	129	150	80	122	29	28	No.0
100	4	100	186	123	94	24	52	149	175	110	135	36	40	No.1
125	5	125	214	151	122	24	56	184	210	110	150	36	40	No.1
150	6	150	226	163	135	24	56	214	240	110	150	36	40	No.1
200	8	196	267	190	161	32	60	258	290	170	180	51	63	No.2
250	10	245	317	239	238	32	68	316	355	170	180	51	63	No.2
300	12	295	342	264	263	32	78	367	400	170	180	51	63	No.2

Long Neck Type

Pneumatically Operated-Double Action Actuator

FA-10XJME (Size: "1 1/2" to "12")
 FA-10XJMEA (Size: "2" to "10")*

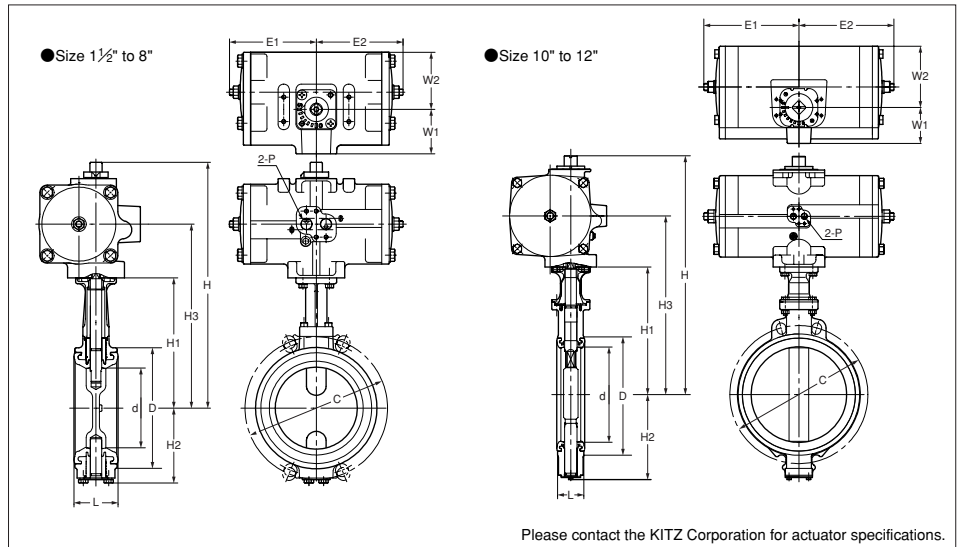

Dimensions

unit : mm

Size		d	H	H1	H2	H3	L	D	C		Actuator					
mm	inch								10K	Class150	E1	E2	W1	W2	P	Type
40	1 1/2	40	251	128	40	181	33	80	105	—	87	87	50	54	Rc 1/4	FA-1
50	2	50	255	132	66	185	43	93	120	120.5	87	87	50	54	Rc 1/4	FA-1
65	2 1/2	65	287	141	74	207	46	118	140	139.5	107	107	54	70	Rc 1/4	FA-2
80	3	80	295	149	83	215	46	129	150	152.5	107	107	54	70	Rc 1/4	FA-2
100	4	100	306	160	94	226	52	149	175	190.5	107	107	54	70	Rc 1/4	FA-2
125	5	125	357	195	122	271	56	184	210	216	128	128	57	87	Rc 1/4	FA-3
150	6	150	369	207	135	283	56	214	240	241.5	128	128	57	87	Rc 1/4	FA-3
200	8	196	435	234	161	327	60	258	290	298.5	160	160	68	111	Rc 1/4	FA-4
250	10	245	573	328	238	441	68	316	355	362	208	208	78	135	Rc 1/4	FA-5
300	12	295	627	353	263	475	78	367	400	—	268	268	101	178	Rc 1/4	FA-6

* JIS 10K and ASME Class 150. Refer to Page 3 for details.

Long Neck Type

Pneumatically Operated-Spring Return Action Actuator

FAS-10XJME (Size: "1 1/2" to "8")
 FAS-10XJMEA (Size: "2" to "8")*

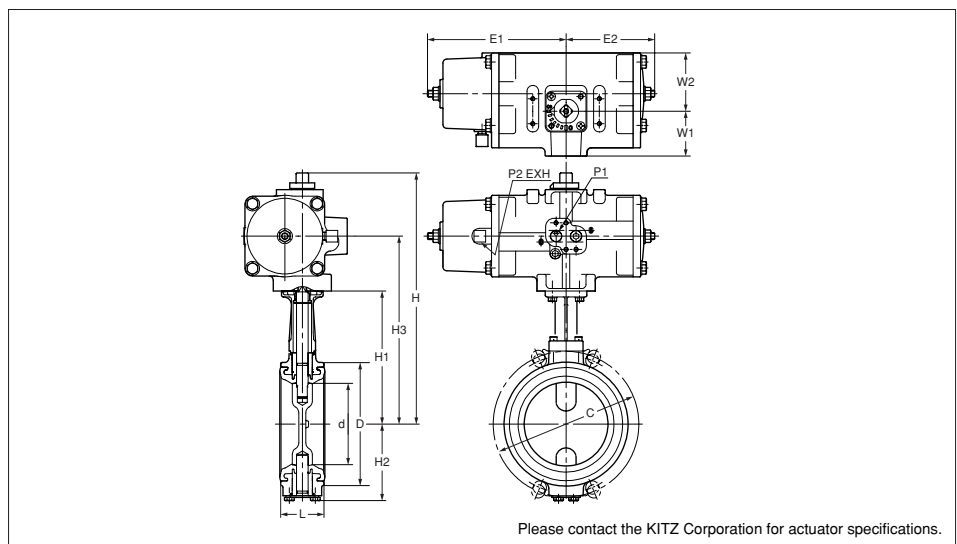

Dimensions

unit : mm

Size		d	H	H1	H2	H3	L	D	C		Actuator						
mm	inch								10K	Class150	E1	E2	W1	W2	P1	P2	Type
40	1 1/2	40	274	128	40	194	33	80	105	—	166	107	54	70	Rc 1/4	Rc 1/8	FAS-2
50	2	50	278	132	66	198	43	93	120	120.5	166	107	54	70	Rc 1/4	Rc 1/8	FAS-2
65	2 1/2	65	303	141	74	217	46	118	140	139.5	203	128	57	87	Rc 1/4	Rc 1/8	FAS-3
80	3	80	311	149	83	225	46	129	150	152.5	203	128	57	87	Rc 1/4	Rc 1/8	FAS-3
100	4	100	364	160	94	256	52	149	175	190.5	290	160	68	111	Rc 1/4	Rc 1/8	FAS-4
125	5	125	396	195	122	288	56	184	210	216	290	160	68	111	Rc 1/4	Rc 1/8	FAS-4
150	6	150	452	207	135	320	56	214	240	241.5	363	208	78	135	Rc 1/4	Rc 1/8	FAS-5
200	8	196	511	234	161	359	60	258	290	298.5	483	268	101	178	Rc 1/4	Rc 1/8	FAS-6

* JIS 10K and ASME Class 150. Refer to Page 3 for details.

Short Neck Type

Pneumatically Operated - Double Action Actuator

FA-10XJSME

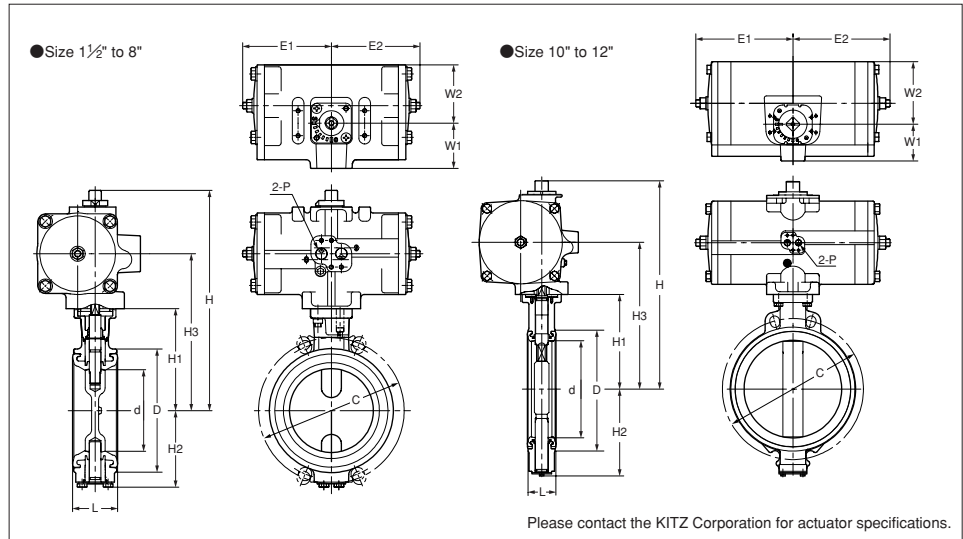

Dimensions

unit : mm

Size		d	H	H1	H2	H3	L	D	C	Actuator					
mm	inch									E1	E2	W1	W2	P	Type
40	1 1/2	40	216	93	40	146	33	80	105	87	87	50	54	Rc 1/4	FA-1
50	2	50	218	95	66	148	43	93	120	87	87	50	54	Rc 1/4	FA-1
65	2 1/2	65	249	103	74	169	46	118	140	107	107	54	70	Rc 1/4	FA-2
80	3	80	258	112	83	178	46	129	150	107	107	54	70	Rc 1/4	FA-2
100	4	100	269	123	94	189	52	149	175	107	107	54	70	Rc 1/4	FA-2
125	5	125	313	151	122	227	56	184	210	128	128	57	87	Rc 1/4	FA-3
150	6	150	325	163	135	239	56	214	240	128	128	57	87	Rc 1/4	FA-3
200	8	196	391	190	161	283	60	258	290	160	160	68	111	Rc 1/4	FA-4
250	10	245	483	238	238	351	68	316	355	208	208	78	135	Rc 1/4	FA-5
300	12	295	537	263	263	385	78	367	400	268	268	101	178	Rc 1/4	FA-6

Short Neck Type

Pneumatically Operated - Spring Return Action Actuator

FAS-10XJSME

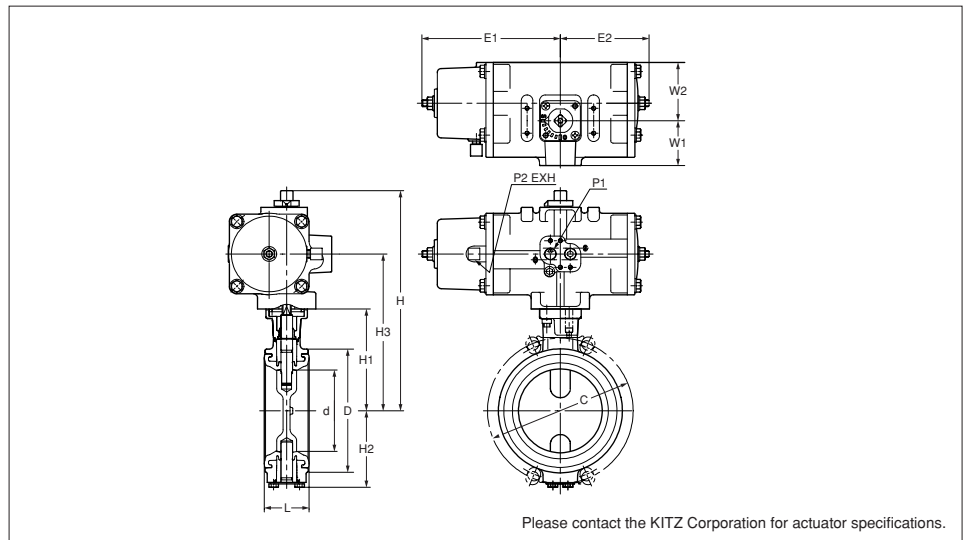

Dimensions

unit : mm

Size		d	H	H1	H2	H3	L	D	C	Actuator						
mm	inch									E1	E2	W1	W2	P1	P2	Type
40	1 1/2	40	239	93	40	159	33	80	105	166	107	54	70	Rc 1/4	Rc 1/8	FAS-2
50	2	50	241	95	66	161	43	93	120	166	107	54	70	Rc 1/4	Rc 1/8	FAS-2
65	2 1/2	65	265	103	74	179	46	118	140	203	128	57	87	Rc 1/4	Rc 1/8	FAS-3
80	3	80	274	112	83	188	46	129	150	203	128	57	87	Rc 1/4	Rc 1/8	FAS-3
100	4	100	327	123	94	219	52	149	175	290	160	68	111	Rc 1/4	Rc 1/8	FAS-4
125	5	125	352	151	122	244	56	184	210	290	160	68	111	Rc 1/4	Rc 1/8	FAS-4
150	6	150	408	163	135	276	56	214	240	363	208	78	135	Rc 1/4	Rc 1/8	FAS-5
200	8	196	467	190	161	315	60	258	290	483	268	101	178	Rc 1/4	Rc 1/8	FAS-6

Long Neck Type *Electrically Operated*

EXS-10XJME (Size: "1 1/2" to "12")
 EXS-10XJMEA (Size: "2" to "10")*



EXS-10XJME

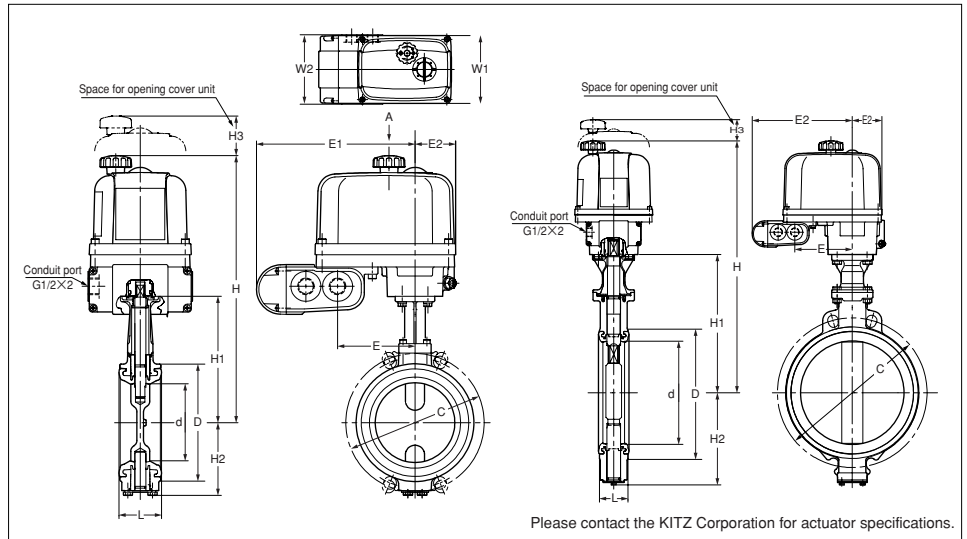

Dimensions

unit : mm

Size		d	H	H1	H2	L	D	C		Actuator						Type
mm	inch							10K	Class150	E	E1	E2	W1	W2	H3	
40	1 1/2	40	309	128	40	33	80	105	—	98	206.5	54	131	132	107.5	EXS-2
50	2	50	313	132	66	43	93	120	120.5	98	206.5	54	131	132	107.5	EXS-2
65	2 1/2	65	322	141	74	46	118	140	139.5	98	206.5	54	131	132	107.5	EXS-2
80	3	80	330	149	83	46	129	150	152.5	98	206.5	54	131	132	107.5	EXS-2
100	4	100	341	160	94	52	149	175	190.5	98	206.5	54	131	132	107.5	EXS-2
125	5	125	401	194.5	122	56	184	210	216	121.5	230	69	158	132	117.5	EXS-3
150	6	150	413.5	207	135	56	214	240	241.5	121.5	230	69	158	132	117.5	EXS-3
200	8	196	440	233.5	161	60	258	290	298.5	121.5	230	69	158	132	117.5	EXS-3
250	10	245	604	328	238	68	316	355	362	137	245.5	73	188	132	153	EXS-4
300	12	295	629	353	263	78	367	400	—	137	245.5	73	188	132	153	EXS-4

* JIS 10K and ASME Class 150. Refer to Page 3 for details.

Short Neck Type *Electrically Operated*

EXS-10XJSME

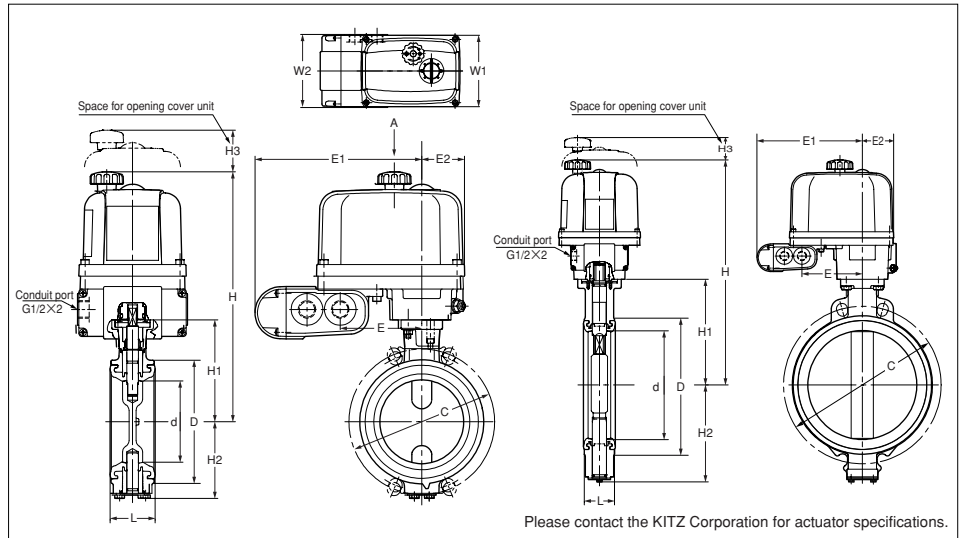

Dimensions

unit : mm

Size		d	H	H1	H2	L	D	C	Actuator						Type
mm	inch								E	E1	E2	W1	W2	H3	
40	1 1/2	40	274	93	40	33	80	105	98	206.5	54	131	132	107.5	EXS-2
50	2	50	276	95	66	43	93	120	98	206.5	54	131	132	107.5	EXS-2
65	2 1/2	65	284	103	74	46	118	140	98	206.5	54	131	132	107.5	EXS-2
80	3	80	293	112	83	46	129	150	98	206.5	54	131	132	107.5	EXS-2
100	4	100	304	123	94	52	149	175	98	206.5	54	131	132	107.5	EXS-2
125	5	125	357.5	151	122	56	184	210	121.5	230	69	158	132	117.5	EXS-3
150	6	150	369.5	163	135	56	214	240	121.5	230	69	158	132	117.5	EXS-3
200	8	196	396.5	190	161	60	258	290	121.5	230	69	158	132	117.5	EXS-3
250	10	245	514	238	238	68	316	355	137	245.5	73	188	132	153	EXS-4
300	12	295	539	263	263	78	367	400	137	245.5	73	188	132	153	EXS-4

Pipes Recommended for Use of Butterfly Valves

When butterfly valves are being opened, movement of discs may be interrupted by internal pipe parts. Where butterfly valves are connected with welded pipe flanges as shown in the illustration to the right, the use of pipes listed in the table to the right is recommended. Valve-to-flange centering work must always be done accurately for valve mounting on pipelines.

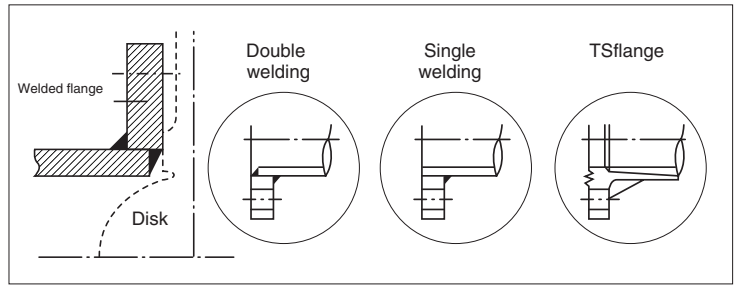

Sizes of Lined Steel Pipes

For vinyl chloride-lined steel pipes, the flange sizes must be larger than the minimum inside diameters given in the table to the right.

For pulverulent polyethylene-lined steel pipes, no adjustments to the flange sizes are needed.

Pipe type		Double welding			Single welding			TS	Minimum Diam of pipe
mm	inch	SGP	Schedule		SGP	Schedule			
			20	40		20	40		
40	1½	●	●	●	●	●	●	●	28
50	2	●	●	●	●	●	●	●	30
65	2½	●	●	●	●	●	●	●	50
80	3	●	●	●	●	●	●	●	70
100	4	●	●	●	●	●	●	●	90
125	5	●	●	●	●	●	●	●	116
150	6	●	●	●	●	●	●	×	144
200	8	●	●	●	●	●	●	×	194
250	10	●	●	●	●	●	●	●	244
300	12	●	●	●	●	●	●	●	292

Boltings Recommended for Use of Butterfly Valves (Boltings used for other than cast iron flanges)

Hexagonal bolt

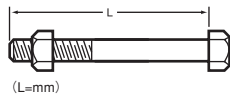

Flange		ASME class 150			EN1092 PN 16			JIS 10K		
mm	inch	Size	L	Pcs.	Size	L	Pcs.	Size	L	Pcs.
40	1½	—	—	—	—	—	—	M16	85	4
50	2	5/8-11	100	4	M16	105	4	M16	95	4
65	2½	5/8-11	105	4	M16	110	4	M16	105	4
80	3	5/8-11	110	4	M16	110	8	M16	105	8
100	4	5/8-11	125	8	M16	115	8	M16	110	8
125	5	3/4-10	130	8	M16	120	8	M20	120	8
150	6	3/4-10	135	8	M20	125	8	M20	125	8
200	8	3/4-10	145	8	M20	130	12	M20	130	12
250	10	7/8-9	160	12	—	—	—	M22	150	12
300	12	—	—	—	—	—	—	M22	160	16

Double bolt

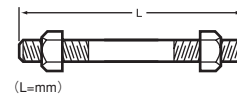

Flange		ASME Class 150			EN1092 PN 16			JIS 10K		
mm	inch	Size	L	Pcs.	Size	L	Pcs.	Size	L	Pcs.
40	1½	—	—	—	—	—	—	M16	105	4
50	2	5/8-11	120	4	M16	125	4	M16	115	4
65	2½	5/8-11	130	4	M16	130	4	M16	120	4
80	3	5/8-11	130	4	M16	130	8	M16	120	8
100	4	5/8-11	145	8	M16	135	8	M16	130	8
125	5	3/4-10	160	8	M16	140	8	M20	145	8
150	6	3/4-10	160	8	M20	145	8	M20	150	8
200	8	3/4-10	170	8	M20	155	12	M20	155	12
250	10	7/8-9	190	12	—	—	—	M22	170	12
300	12	—	—	—	—	—	—	M22	180	16

★Please contact the KITZ Corporation when cast iron flanges are used.

Memo

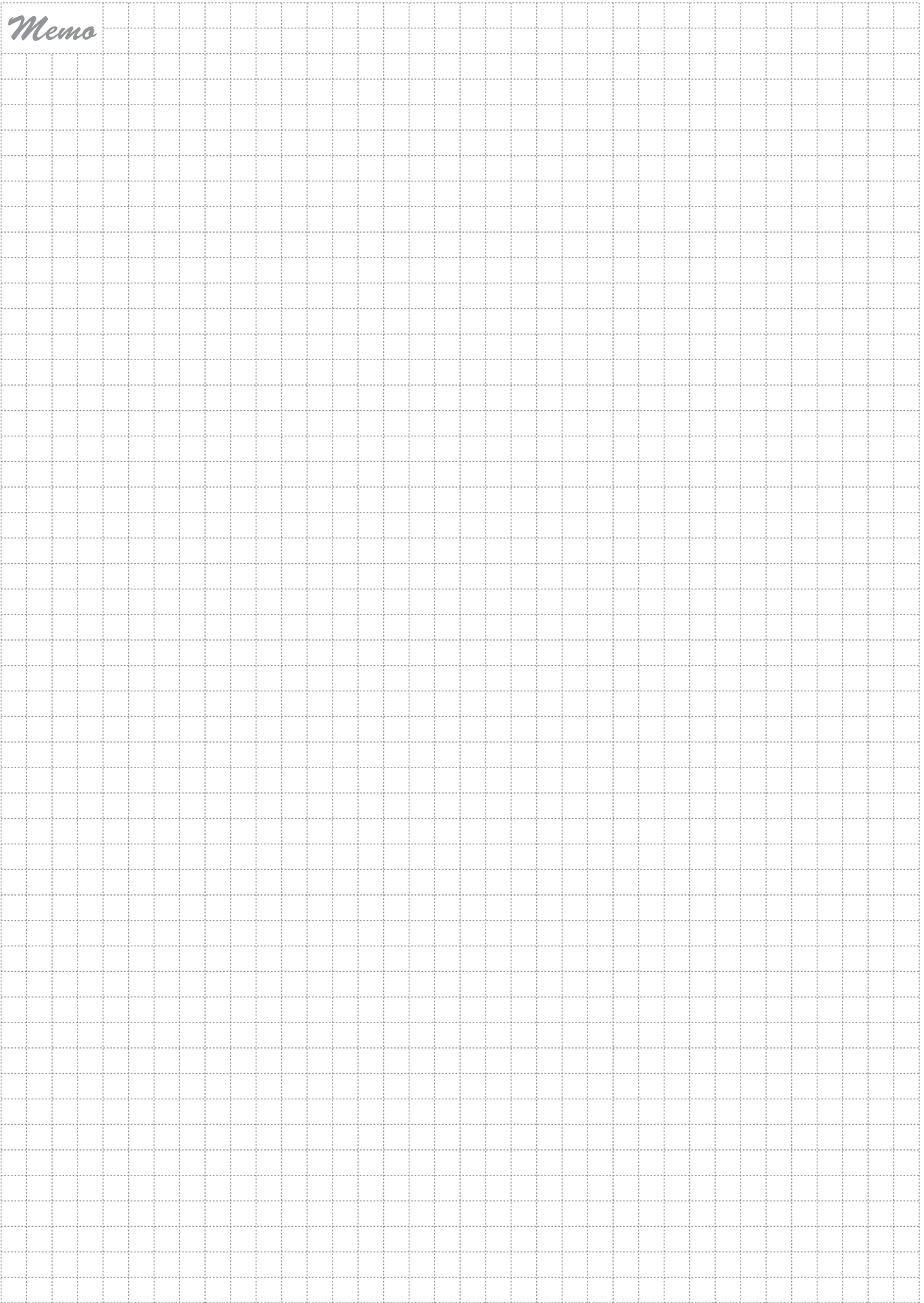

Precautions for Trouble-free Operation of KITZ Butterfly Valves

Valve Selection

- 1 Make sure to select a valve with design specifications that are appropriate for the fluid type and the pressure and temperature conditions expected.
- 2 Lubricants are applied to discs and rubber seats to protect their surfaces. Oil-free treated types are also available. Contact the KITZ Corporation or one of its local distributors for details.
- 3 Contact the KITZ Corporation or one of its local distributors for service with fine particles.

Storage and Handling

- 1 Valves must be stored in a clean, dry, corrosion-free environment with no direct exposure to sunlight. Valves should be left open 10° to prevent permanent distortion of the resilient seats. Refrain from overloading valves and their actuators by storing them in piles or placing other objects on them.

Mounting on Pipelines

- 1 Valves must be mounted on flanges only after flanges have been welded to pipes and cooled down to the ambient temperature. Otherwise, the welding heat may affect the quality of the resilient seats.
- 2 The edges of welded flanges must be machined to achieve a smooth surface finish so that they will not damage the resilient seats during valve mounting. Flange faces must be free from damage or deformation and must be cleaned to remove rust and any foreign objects to prevent leakage through the valve and flange connections. Gaskets are not required for mounting KITZ XJ series butterfly valves.
- 3 Flanges and pipe bores must be cleaned thoroughly to remove welding spatters, scales, and foreign objects that may have been left inside.
- 4 Accurate centering of each pair of upstream and downstream pipes is essential for trouble-free operation of the valves mounted between them. Incorrect centering, shown in Fig. 1, must be avoided at all costs.

Fig.1

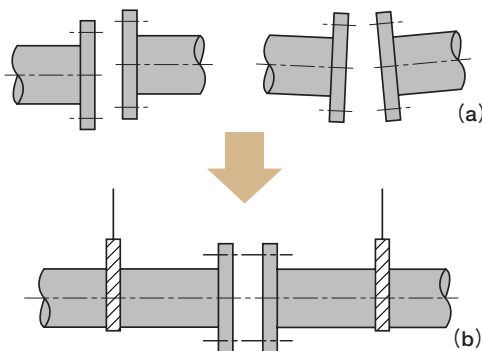

- 5 When mounting valves, set jack bolts under the pipes to provide support at a consistent height and adjust the flange-to-flange distance to allow 6 to 10 mm of space on each side of the valve body. Remember that valves must be left open 10° from the fully closed position (Fig. 2).
- 6 Set two bolts into the lower mounting guides of a valve and mount it carefully so that the flange faces do not damage the resilient seats.
- 7 Next, set another two bolts into the upper mounting guides of the valve, ensuring the correct centering between the pipes and the valve.
- 8 Try opening the valve to check that there is no obstructing contact between the valve disc and the flanges.
- 9 Remove the jack bolts, set all bolts around the valve body, and tighten the bolts alternately and diagonally until the flanges come into contact with the valve body (Fig. 3). Refer to the table shown below for recommended torque values.

Fig.2

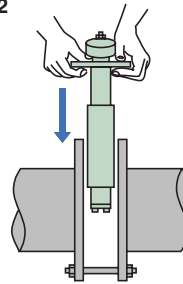

Recommended torque values

DN	N · m (kgf · m)
40	49 (5)
50	
65	
80	
100	
125	88 (9)
150	
200	
250	118 (12)
300	

Fig.3

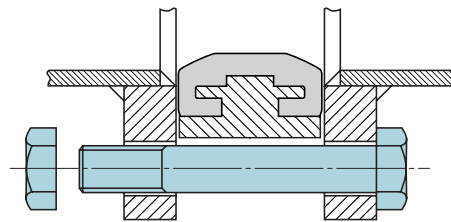

- 10 For mounting actuated valves, provide valve supports to prevent bending of valve necks and reduce valve and pipe vibration.
- 11 Do not step on valve necks or valve hand-wheels.
- 12 Do not mount butterfly valves directly on check valves or pumps; this may result in damage caused by the disc contacts.
- 13 Do not mount valves on the downstream sides of elbows, reducers, or regulating valves where the fluid velocity changes. It is recommended that valves be installed at distances of approximately 10 times the nominal valve sizes in such cases.

- 14 Mount valves taking into consideration the effects on discs of fluid velocity or pressure changes in the piping. Refer to the illustrations (Fig. 4).
- 15 Contact the KITZ Corporation or one of its local distributors for details.

Fig.4

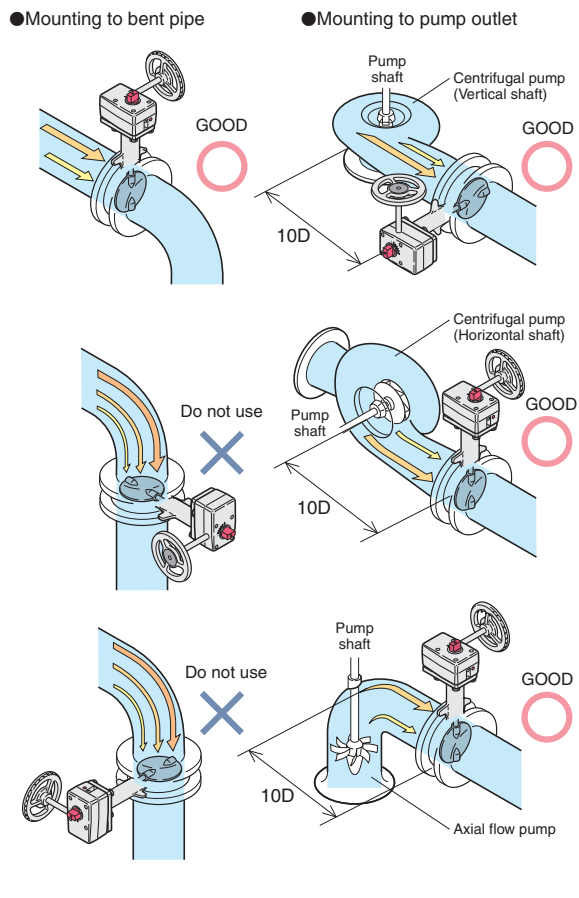

Note:
Centering with centering sleeves is required for valves equipped with such sleeves for accurate centering (Fig. 5) Refer to page 3 for applicable sizes.

Fig.5

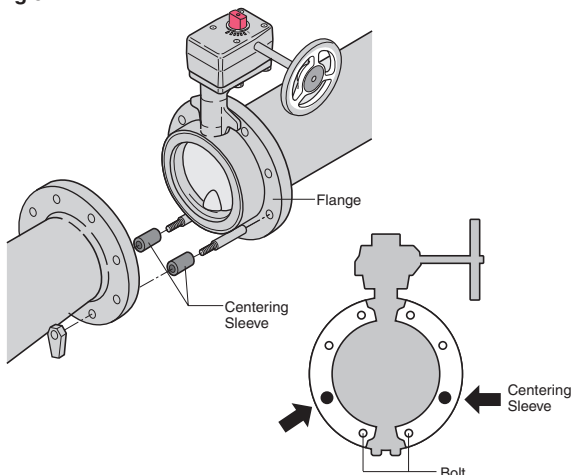

Valve Operation

- 1 Valves equipped with manual operators, such as levers, handles and gears, must be **MANUALLY OPERATED ONLY**. Application of excessive external force to operate valves may result in malfunction of valves and their operators.
- 2 Make sure to open valves fully before conducting a loop test of the piping system at a line pressure higher than the nominal pressure of the tested valves. Never use closed valves in place of blind flanges.
- 3 When valves need to be removed from pipes for maintenance or for any other reason, make sure to thoroughly relieve the line pressure beforehand. Loosening piping bolts under line pressure is dangerous. Any residual fluid left inside the pipeline must be completely drained.
- 4 Users should contact the KITZ Corporation or one of its local distributors for technical advice when valves need to be continuously pressurized while left open 30° or less.
- 5 Do not use position indicators to operate valves or overload position indicators. These actions may cause damage to the indicators.
- 6 Make sure to use blind flanges when butterfly valves are mounted at the ends of pipelines.
- 7 Standard actuators are referenced in this catalog for actuated valve operation. Contact the KITZ Corporation or one of its local distributors for information on mounting optional actuators.
- 8 Contact the KITZ Corporation for service at hopper or pump outlets.
- 9 Avoid touching gear operators and actuator stopper bolts accidentally.
- 10 Periodic inspection is recommended to
 - Check the valve opening degree
 - Check loosened bolts and leakage at each connection
 - Check vibration and noise
- 11 Refer to the instruction manual for other precautions. Refer to actuator catalogs and instruction manuals for actuated valves.

WARNING

To prevent stem blow-out, do not disassemble necks while a valve is pressurized. Do not dismantle valve operating devices because this may cause valve discs to rotate and may result in valve malfunction.

CAUTION

Pressure-temperature ratings and other performance data published in this catalog have been developed from our design calculations, in-house testing, field reports provided by our customers, and/or published official standards or specifications. These data apply only to typical applications and are provided as general guidelines to users of KITZ products introduced in this catalog.

For any specific application, users are kindly requested to contact the KITZ Corporation for technical advice or to carry out their own study and evaluation to ensure the suitability of these products for such an application. Failure to follow this request could result in property damage and/or personal injury for which we shall not be liable.

While this catalog has been compiled with utmost care, we assume no responsibility for errors, impropriety, or inadequacy. Any information provided in this catalog is subject to change without notice for error rectification, product discontinuation, design modification, new product introduction, or any other cause that the KITZ Corporation considers necessary. This edition supersedes all previous editions.

Read instruction manuals carefully before using KITZ products.

NOTICE

If any products designated as strategic materials in the Foreign Exchange and Foreign Trade Law, Cabinet Order Concerning Control of Export Trade, Cabinet Order Concerning Control of Foreign Exchange or other related laws and ordinances ("Foreign Exchange Laws") are exported to any foreign country or countries, an export license issued by the Japanese Government will be required under the Foreign Exchange Laws.

Furthermore, there may be cases in which an export license issued by the Government of the United States or the government of another country will be required under the applicable export-related laws and ordinances of that country.

The contract shall become effective subject to a relevant export license being obtained from the Japanese Government.

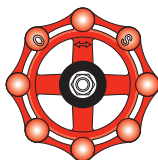

*A chrysanthemum-handle is a symbol of KITZ,
the brand of valve reliability*

ISO 9001 certified since 1989

KITZ
KITZ CORPORATION

1-10-1, Nakase, Mihama-ku, Chiba 261-8577, Japan
International Sales Dept.

Phone : 81-43-299-1730, 1732 and 1733

Fax : 81-43-299-0121

— Distributed by —