

AL-10

3 Safety Relief Valve

- Full bore type **Lift type** **Safety valve** Relief valve
- Safety relief valve **Lever type** Closed type Dash-pot structure
- Handle type Stainless High pressure gas testing products
- Diaphragm Non-leakage

■Features

1. Compact and lightweight lift safety valve, installation is easy.
2. Simple structure and easy maintenance.
3. Due to lift valve lever mechanism a discharge inspection can be manually performed at more than 75% of the opening pressure (open type with a lever).
4. Blowdown can be adjusted with adjustable ring (seat ring).



Open type with a lever



Open type without a lever

■Specifications

Structure	Open type	
Application	Steam	
Working pressure	0.05-1.0 MPa	
Maximum temperature	220°C	
Material	Spring case	Ductile cast iron
	Valve, valve seat	Cast bronze or stainless steel
Connection	JIS Rc screwed	

· Please refer to the chart in P.3-76 for set pressure range.

■Dimensions and Weights

Nominal size	Dimension (mm)						Flow area πD_L^2 (mm ²)	Weight (kg)
	d	L	H ₁	H _L	H _x	D		
15A	Rc 1/2	40	40	154	142	16	20.1	1.0
20A	Rc 3/4	45	50	173	161	21	34.6	1.5
25A	Rc 1	50	60	193	181	26	53.0	1.8
32A	Rc 1-1/4	60	70	232	219	33	85.5	3.1
40A	Rc 1-1/2	65	75	250	237	41	132.0	4.5
50A	Rc 2	80	85	284	271	51	204.2	6.2

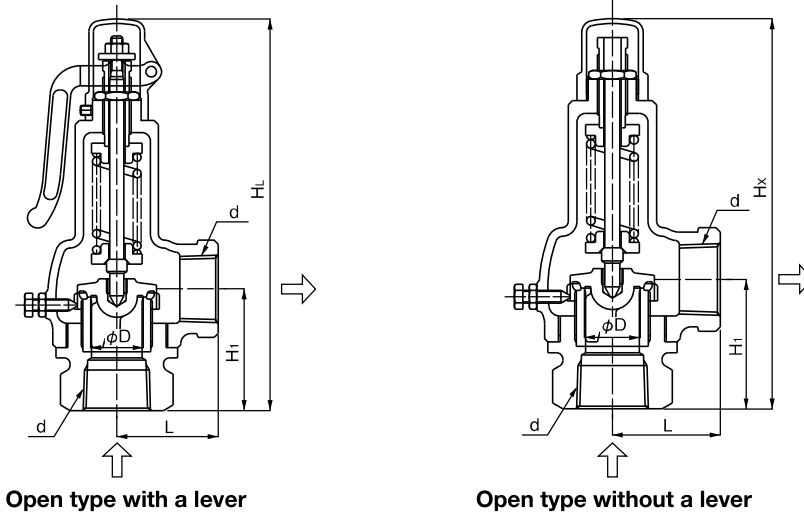

■ Certified Capacity Table

· For steam (saturation temperature) <Pressure vessel structure standard>

(kg/h)

Nominal size \ Pressure MPa	0.05	0.1	0.2	0.3	0.4	0.5	0.6	0.7	0.8	0.9	1.0
15A	15	20	29	40	50	60	70	80	90	100	109
20A	27	35	51	69	87	104	121	138	155	172	189
25A	42	54	78	105	133	159	186	212	237	263	289
32A	67	87	127	170	215	257	300	342	383	425	467
40A	104	135	196	263	332	397	463	528	592	656	721
50A	161	209	303	407	513	615	716	817	916	1016	1116

· Please refer to P.3-11 for the calculation procedure for nominal size selection.

■ At the Time of Ordering

When ordering, please specify with or without lever and the material of the valve body and valve seat in addition to the set pressure.