

GP-2000CS

Direct type	Pilot type	Piston	Diaphragm
Bellows	Internal sensing	External sensing	Stainless steel
With handle	Built-in strainer	Low pressure	Remote
Valve leakage 0	Nylon		



■Features

1. The GP-2000CS pressure reducing valve for steam is pilot operated diaphragm type, which can control larger flow of fluid than piston type, offering superior controllability for pressure fluctuation of inlet side or load fluctuation of outlet side.
2. 200 mesh integral strainer prevents most scale problem on the pilot valve.
3. Spherical valve provides a tight seal meeting ANSI Class IV.

■Specifications

Model		GP-2000CS			
Application		Steam			
Reduced pressure sensing method		External sensing*			
Max. inlet pressure		3.0 MPa	1.0 MPa	2.0 MPa	3.0 MPa
Reduced pressure		0.02-0.15 MPa	0.02-0.15 MPa	0.02-0.15 MPa	0.02-0.15 MPa
		0.1-1.4 MPa	0.1-0.85 MPa	0.1-1.4 MPa	0.1-1.4 MPa
		1.3-2.0 MPa		1.3-1.7 MPa	1.3-2.0 MPa
		85% or less of inlet pressure (gauge pressure)			
Minimum differential pressure		0.05 MPa			
Maximum pressure reduction ratio		20:1			
Maximum temperature		260°C			
Valve seat leakage		0.01% or less of rated flow rate			
Material	Body	Cast carbon steel			
	Main valve, valve seat	Stellite overlaid stainless steel			
	Pilot valve, pilot valve seat	Stainless steel			
	Diaphragm	Stainless steel			
Connection		JIS Rc screwed	JIS 10K FF flanged	JIS 20K RF flanged	JIS 30K RF flanged

* Please have a sensing pipe at your end.

Joint size is below:

JIS Rc, JIS SW, JIS 10K FF, 20K RF and 30K RF: Rc 1/4

NPT, ASME class 150 and 300: NPT 1/4

Make the length the sense of piping less than 5 m.

When installing the pressure reducing valve, be sure to connect the sensing pipe and joint. Unless the sensing pipe is connected, the valve will not operate.

· Available with SW (socket weld) for 15-50A.

· Available with ASME or EN flanged.

■ Dimensions (mm) and Weights (kg)

· JIS Rc screwed

Nominal size	d	L	H	H ₁	Weight
15A	Rc 1/2	150	398	170	16
20A	Rc 3/4	150	398	170	16
25A	Rc 1	160	404	175	21.5
32A	Rc 1-1/4	180	434	192	24
40A	Rc 1-1/2	180	434	192	24
50A	Rc 2	230	498	216	37

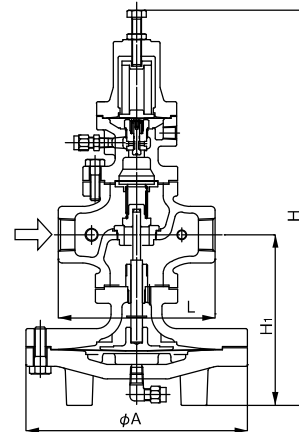

· JIS 30K RF flanged

Nominal size	L	H	H ₁	Weight
50A	230	498	216	42
65A	294	552	251	75
80A	314	575	264	84
100A	358	658	321	133

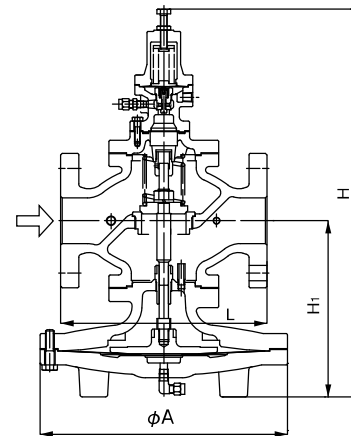

· Welded flanged type

Nominal size	L	H	H ₁	A	Weight
15A	240	398	170	200	18.0
20A	240	398	170	200	18.0
25A	250	404	175	226	24.5
32A	260	434	192	226	27.0
40A	260	434	192	226	27.0
50A	320	498	216	276	40.0

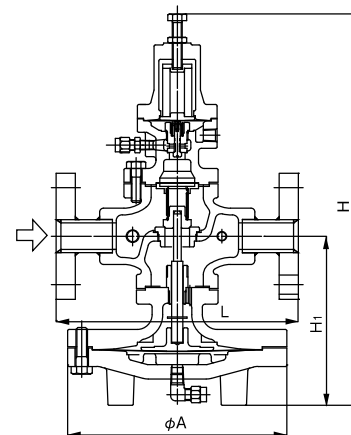

Specifications Selection Chart

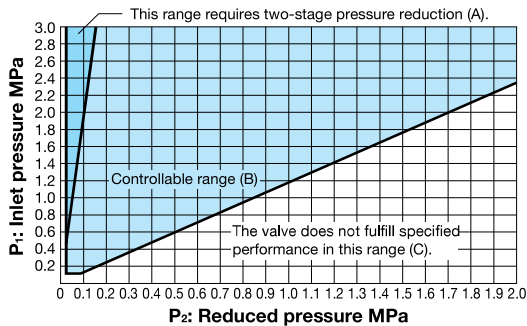

Based on the selection chart above, select a pressure reducing valve in the optimum manner. On the selection chart, first find the intersection point of the inlet pressure (P₁) and the reduced pressure (P₂). Two-stage pressure reduction is required if the intersection point lies in range (A), or the pressures are controllable with a single pressure reducing valve if the intersection point is within range (B). The valve does not fulfill specified performance in range (C). To adopt two-stage pressure reduction, separate two pressure reducing valves as far away from each other as possible.

Flow Characteristic Chart

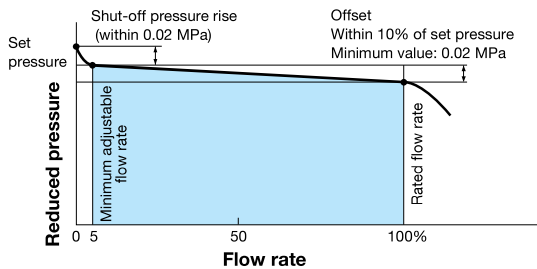

When selecting a nominal size, set the flow rate at 80 to 90% of the rated flow rate, allowing for the pressure loss and heat loss of the stop valve, strainer, etc. to be used before or after the pressure reducing valve. To enable the pressure reducing valve to show a maximum flow characteristic, do not select a small piping diameter, as a countermeasure against the effect of piping resistance. Select a nominal size based on the nominal sizes selection chart.

Pressure Characteristic Chart

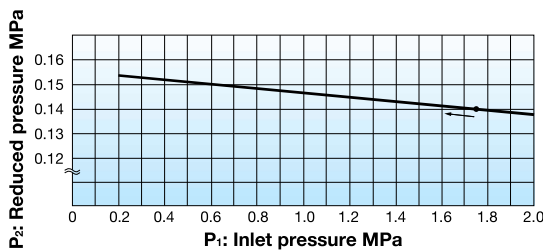

This chart shows variation in reduced pressure when the inlet pressure of 1.75 MPa is changed between 0.2 MPa and 2.0 MPa while the reduced pressure is set at 0.14 MPa.

· Set pressure of safety valve for alarm use at the outlet side of the pressure reducing valve for steam

Set pressure of pressure reducing valve (MPa)	Set pressure of safety valve (MPa)
0.1 or less	Set pressure of the pressure reducing valve + 0.05 or more
0.11-0.4	Set pressure of the pressure reducing valve + 0.08 or more
0.41-0.6	Set pressure of the pressure reducing valve + 0.1 or more
0.61-0.8	Set pressure of the pressure reducing valve + 0.12 or more
More than 0.8	Set pressure of the pressure reducing valve + 15%

· When a safety valve is installed for alarm use at the outlet side of a pressure reducing valve for steam and there are no laws or regulations specified to comply with, select a safety valve whose blowout capacity is around 10% of the maximum flow rate of the pressure reducing valve.

■ Nominal Sizes Selection Chart (For Steam)

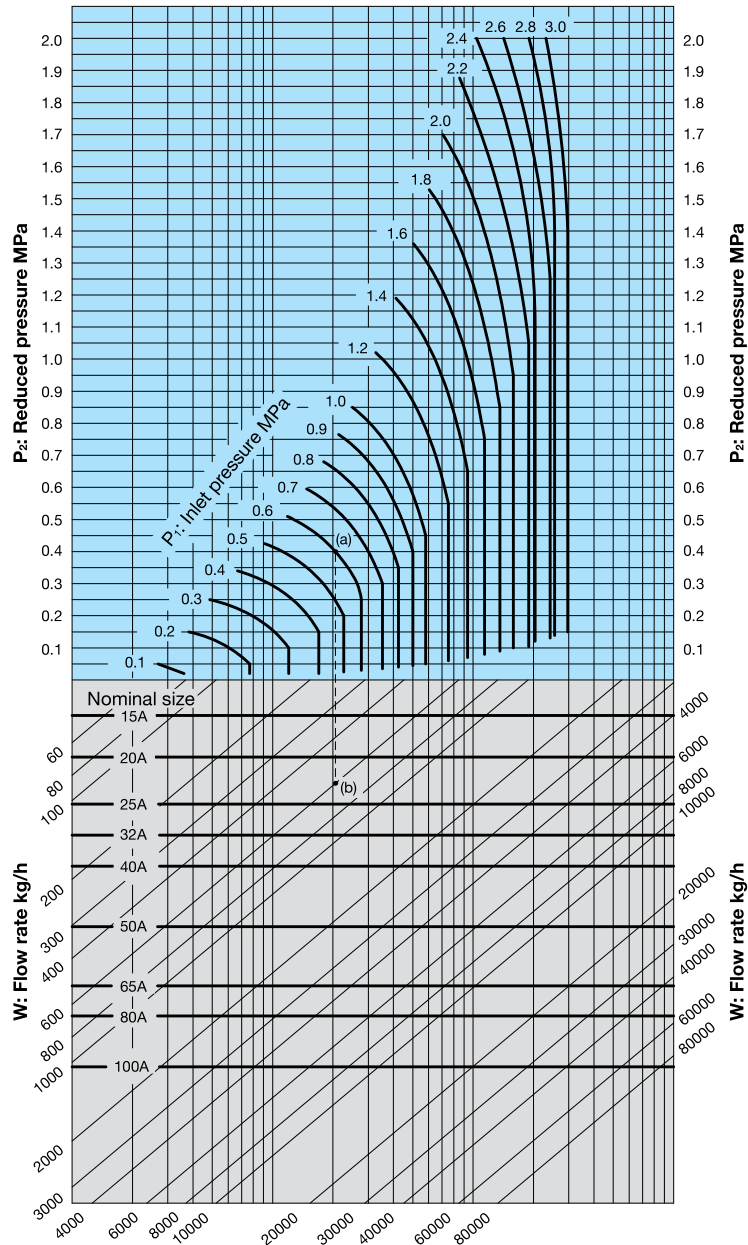

[Example]

When selecting the nominal size of a pressure reducing valve whose inlet pressure (P₁), reduced pressure (P₂), and flow rate are 0.6 MPa, 0.4 MPa, and 600 kg/h, respectively, first find intersection point (a) of the inlet pressure of 0.6 MPa and the reduced pressure of 0.4 MPa. Trace down vertically from this intersection point to find intersection point (b) with the flow rate of 600 kg/h. Since intersection point (b) lies between nominal sizes 20A and 25A, select the larger one, 25A.

* Set the safety factor at 80 to 90%.