



特徵 FEATURES

- 結構長度 FACE TO FACE DIMENSION:ANSI B16.10
- 法蘭規範 END FLANGE DIMENSION:ANSI B16.5
- 設計製造 DESIGN:ANSI B16.34
- 檢查與測試 TEST:API 598
- 帶ISO 5211平臺座 WITH ISO 5211 MOUNTING PAD
- 精密鑄造 INVESTMENT CASTING BODY
- 防爆軸心/全流量 BLOW-OUT PROOF STEM/FULL PORT
- 杠杆操作/齒輪操作 LEVER OPERATED OR GEAR OPERATED

測試壓力 TEST PRESSURE

殼體(水) SHELL(BY WATER)		450PSI
		32kg/cm ²
閥座 SEAT	水 BY WATER	315PSI
	氣體 BY AIR	22kg/cm ²
		168PSI
		11.81kg/cm ²

材質表 MATERIALS LIST

NO.	部件名稱	PART NAME	材料	MATERIALS
1	閥體	BODY	FC20 WCB	CF8 CF8M
2	閥蓋	CAP	FC20 WCB	CF8 CF8M
3	銅球	BALL	CF8	CF8 CF8 CF8M
4	球墊	SEAT		PTFE
5	軸心	STEM	SUS304	SUS304 SUS304 SUS316
6	大薄片	GASKET		PTFE
7	小薄片	THRUST WASHER		PTFE
8	中口	PACKING		PTFE
9	牛棉襯套	STEM PACKING		PTFE
10	牛棉	GLAND		CF8
11	牛棉螺栓	GLAND BOLT		SUS304
12	把手	HANDLE		WCB
13	桃形擋片	STOPPER		SUS304
14	C形扣環	SNAP RING		SUS304
15	體蓋螺栓	BOLT		SUS304
16	把手螺栓	HANDLE BOLT		SUS304
17	把手套	PLASTIC COVER		PLASTIC

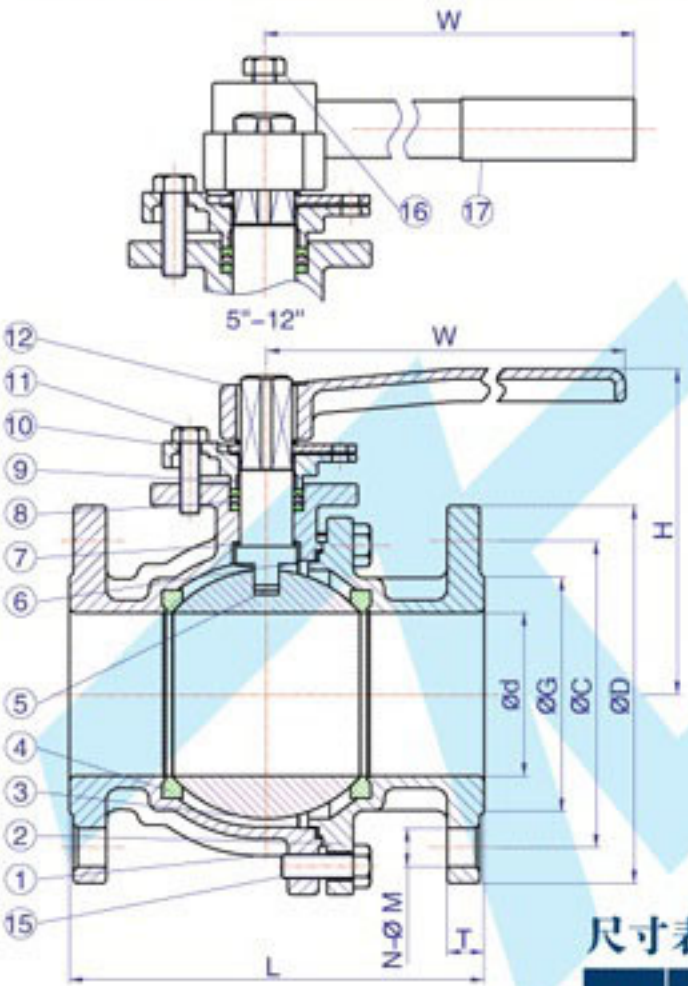

尺寸表 DIMENSIONS

SIZE	d	D	C	G	T		N-ØM	L	H	W	W1	J	ISO 5211	K	Ma
					FC	SUS									
1/2"	15	89	60.5	35	12.1	12.1	4-Ø16	108	70	160	12	50	F04	42	M5
3/4"	20	98	70.0	43	12.7	12.1	4-Ø16	117	73	160	12	50	F04	42	M5
1"	25	108	79.5	51	14.3	12.1	4-Ø16	127	77	160	12	50	F05	50	M6
1 1/4"	32	117	89.5	64	14.9	12.7	4-Ø16	140	85	160	12	50	F05	50	M6
1 1/2"	40	127	98.5	73	17.5	14.3	4-Ø16	165	104	186	17	62	F07	70	M8
2"	50	152	120.5	92	19.1	15.9	4-Ø19	178	114	186	17	62	F07	70	M8
2 1/2"	65	178	139.5	105	22.3	17.5	4-Ø19	190	142	324	21	75	F07	70	M8
3"	80	190	152.5	127	23.9	19.1	4-Ø19	203	153	324	21	75	F10	102	M10
4"	100	229	190.5	157	23.9	23.9	8-Ø19	229	166	324	21	75	F10	102	M10
5"	125	254	216.0	186	23.9	23.9	8-Ø22	356	224	750	24	89	F12	125	M12
6"	150	279	241.5	216	25.4	25.4	8-Ø22	394	247	750	24	89	F12	125	M12
8"	200	343	298.5	270	28.6	28.6	8-Ø22	457	305	1000	32	100	F12	125	M12
10"	250	406	362.0	324	30.2	30.2	12-Ø25	533	327	1000	32	100	F14	140	M16
12"	300	483	432.0	381	31.8	31.8	12-Ø25	610	355	1000	32	100	F14	140	M16

