

# KITZ-ELECTRIC ACTUATOR KELMO, 10K CAST STAINLESS STEEL BALL VALVES

**KITZ Fig: EXH200-10UTDZ**

Sizes: 2 1/2-inch(65-mm)

ANTI-STATIC DEVICE, FULL BORE, CONFORM TO ISO5211, FLANGED ENDS.

**Standards**

- . End to End: ASME B16.10 CLASS 150
- . End Connection: JIS B2220 10K
- . Wall Thickness: ASME B16.34 CLASS 150
- Test Standard
- . KITZ STANDARD

**Dimensions**

SIZE (inch/mm)		L	L1	H	D1	Kg
2 1/2	65	190.0	85.0	412.0		
3	80	203.0	94.0	421.0		
4	100	229.0	110.0	450.0		
5	125	356.0	150.0	547.0		
6	150	394.0	175.0	580.0		
8	200	457.0	220.0	655.0		



**Material List**

NAME OF PART	MATERIAL	SPECIFICATION
BODY	STAINLESS STEEL	A351 Gr. CF8/SCS13A
BODY CAP	STAINLESS STEEL	A351 Gr. CF8/SCS13A
STEM	STAINLESS STEEL	304SS
BALL	STAINLESS STEEL	304SS

**Specifications**

KITZ-ELECTRIC ACTUATOR KELMO, 10K CAST STAINLESS STEEL BALL VALVES, ANTI-STATIC DEVICE, FULL BORE, CONFORM TO ISO5211, FLANGED ENDS.

End to End : ASME B16.10 CLASS 150, End Connection : JIS B2220 10K, Wall Thickness : ASME B16.34 CLASS 150, Test Standard : KITZ STANDARD, Sizes : 2 1/2-inch(65-mm), BODY MATERIAL : STAINLESS STEEL, BODY CAP MATERIAL : STAINLESS STEEL, STEM MATERIAL : STAINLESS STEEL, BALL MATERIAL : STAINLESS STEEL, KITZ Fig : EXH200-10UTDZ

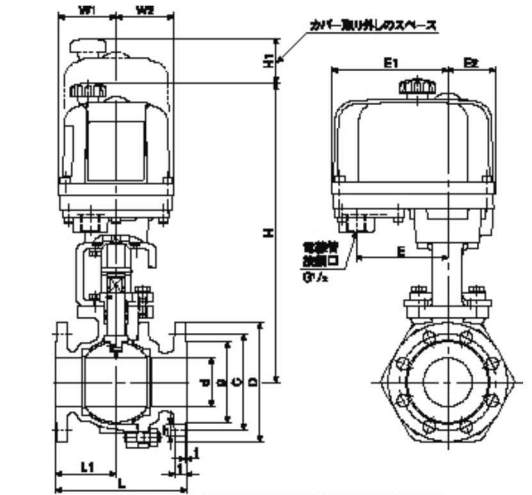

For more details, please refer to the drawing.

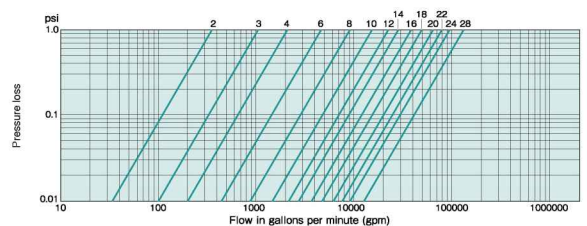

Pressure-temperature ratings and other performance data published in this catalog have been developed from our design calculation, in-house testing, field reports provided by our customers and/or published official standards or specifications. They are good only to cover typical applications as a general guideline to users of KITZ products introduced in this catalog. For any specific application, users are kindly requested to contact KITZ Corporation for technical advice, or to carry out their own study and evaluation for proving suitability of these products to such an application. Failure to follow this request could result in property damage and/or personal injury, for which we shall not be liable. Read instruction manual carefully before use.

