

DST-1S/1F | Thermodynamis Type Steam Trap

- Insulation chamber (air warm) is adopted to lessen the affect of atmosphere and to improve the most suitable working conditions
- The maintenance and repair of disc and seat are easy owing to its material of high-hardness-treated stainless steel and its replaceable seat.

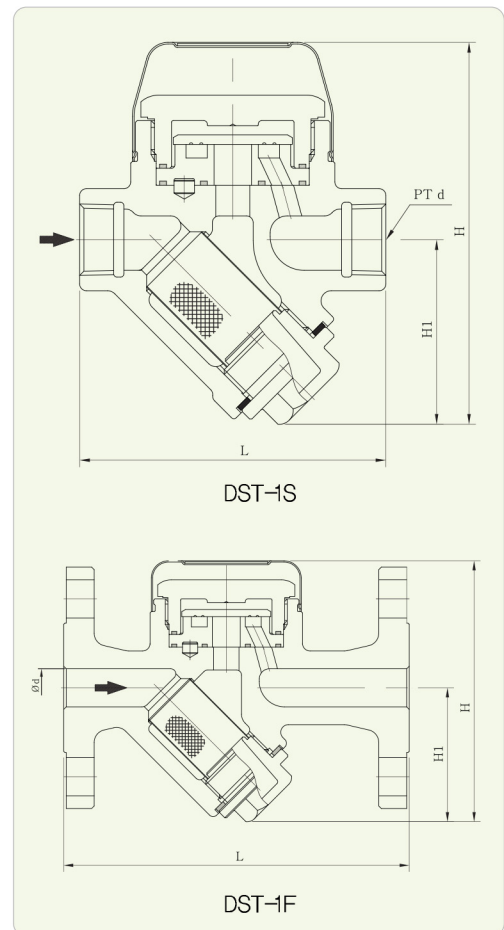

► Specifications

Working Pressure	Max. 16 kgf/cm ²
	Min. 0.35 kgf/cm ²
Working Temperature	Max. 220°C
Connection	DST-1S : PT Screwed
	DST-1F : JIS Flanged
Materials	Body : Ductile Iron
	Trim : Stainless Steel

► Dimensions

Model	Size	d	L	H1	H	Connection
DST-1S	15A	PT 1/2"	90	54	104	PT Screwed
	20A	PT 3/4"	95	56	108	
	25A	PT 1"	100	58	112	
	32A	PT 1 1/4"	180	100	180	
	40A	PT 1 1/2"	180	110	205	
DST-1F	15A	15	136	53	103	JIS 16K Flanged
	20A	20	140	55	108	
	20A	25	150	58	113	
	32A	32	190	103	185	
	40A	40	260	112	206	
	50A	50	260	112	206	

